

Austin St. Andrews Ball 2019

1 JOIE DE VIVRE J32 · 3/4L

Irene van Maarseveen: RSCDS XXXIX 2 · Crib: E-cribs · Diagram: Keith Rose's Diagrams

- 1- 1c set | cast (2c up) ; dance between 3c and cast up to (2,1,3)
- 9- All turn P RH to sidelines ; all chase clw half round (to 3x,1x,2x)
- 17- All dance BtoB ; all set | all ½ RH turn into
- 25- 3c+1c+2c Allemande (2,1,3)

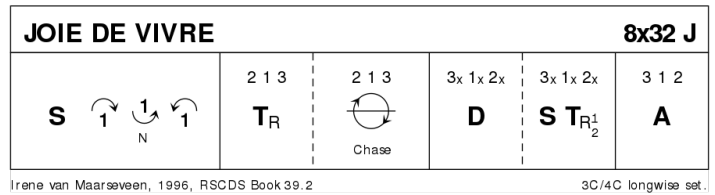

2 THE SAILOR R32 · 3/4L

RSCDS XXIV 4 · Crib: E-cribs · Diagram: Keith Rose's Diagrams

- 1- 1c cross down RH (2c up) to 2plx and BiL with cnrs ; 1c cast R into lines across | all set
- 9- All Reels3 across, Rsh to 1cnr, finishing (2,1x,3)
- 17- 1c lead down | lead to the top ; cross and cast to (2,1,3)
- 25- 2c+1c R&L.

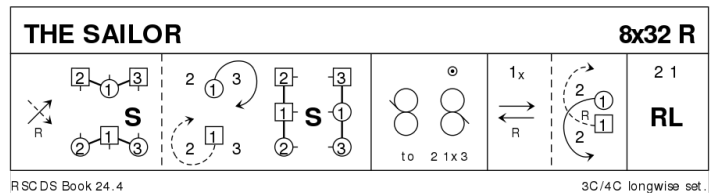

Note: [3-4] is NOT in DT_r position.

3 SEANN TRIUBHAS WILLICHAN S32 · 2/4L

Thomas (19C) Wilson: RSCDS XXVII 9 · Crib: E-cribs · Diagram: Keith Rose's Diagrams

- 1- 1c cast off behind own lines and cast back
- 9- 1W+2M set and change places RH **while**{4} 1M+2W change places RH and set ; repeat
- 17- 1c lead down the middle | turn RH ; lead up and cast off to 2pl (2c up)
- 25- 2c+1c set | turn BH ; open into circle4 L.

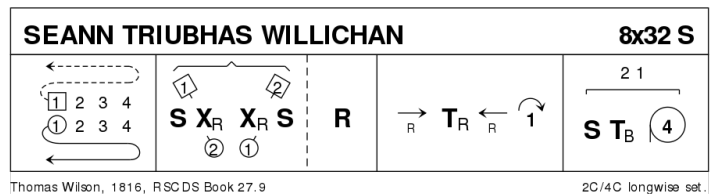

4 PELORUS JACK J32 · 3/4L

Barry Skelton: RSCDS XLI 1 · Crib: E-cribs · Diagram: Keith Rose's Diagrams

- 1-- 1c cross RH, cast (2c up) ; 1c+3c RHA, finish 1M facing 1cnr, 1W behind him
- 9-- 1c in tandem +1cnrs ½ diagonal Reel3, Rsh to 3W (1M & 1W loop R singly for lead change, so 1W now leads P) ; ½ diagonal Reel3, Rsh to 2W (+ lead change)
- 17-- Continue pattern twice
- 25-- 2c+1c LHA ; 1c turn LH ½ | all set (2,1,3)

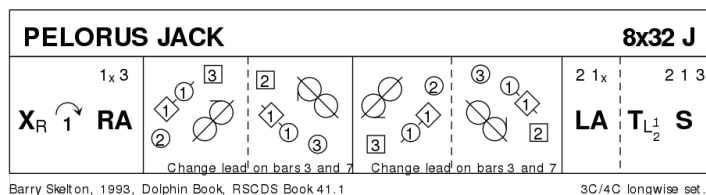

5 AMANDA MAE'S STRATHSPEY S32 · 2/3L

Aase Hansen: 25th Anniversary · Crib: E-cribs · Diagram: Keith Rose's Diagrams

- 1-- 1W+2M set adv. | turn BH ¾ and twirl R to face cnr on 1diag ; set to cnr | turn BH ½ to sidelines (all have moved 1 place cclw in the square)
- 9-- 1M+2W repeat [1-8], finish (2x,1x)
- 17-- 2c ½ Fig8 round 1c ; 1c ½ Fig8 round 2c (2,1)
- 25-- 2c+1c Poussette (2,1)

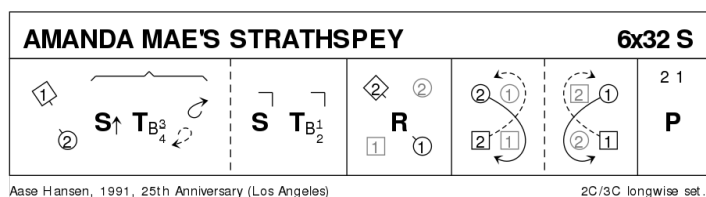

note: on bar 12 M face M, W face W

6 FLOWERS OF EDINBURGH R32 · 3/4L

RSCDS I 6 · Crib: E-cribs · Diagram: Keith Rose's Diagrams

- 1-- 1W followed by 1M casts off 2, 1W crosses below 3c and casts up M side while 1M dances up the middle, both to P's place {6} | 1c set
- 9-- 1c repeat with 1M casting, finishing in original places
- 17-- 1c lead down the middle and up
- 25-- 1c+2c Poussette

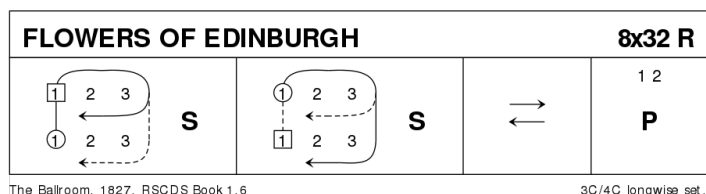

7 THE LAIRD OF MILTON'S DAUGHTER J32 · 3/4L

Craigmyle: RSCDS XXII 10 · Crib: E-cribs · Diagram: Keith Rose's Diagrams

- 1-- 1c set, cross RH ; cast off (2c up), turn LH to 1cnrs
- 9-- Corners' chain: 1c+1cnrs turn ½ RH | 1cnrs turn LH ; 1c+1cnrs turn back RH ½ | 1c turn LH 1¼ to 2cnrs
- 17-- Repeat with 2cnrs, 1c crossing LH to 2pl
- 25-- 2c+1c+3c circle6 and back

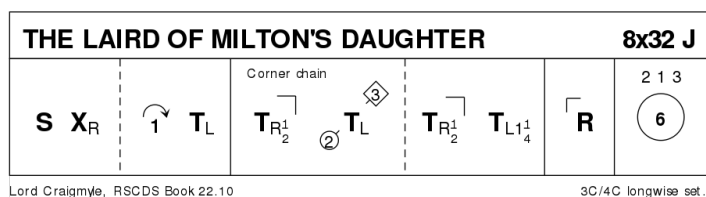

8 TRIP TO TIMBER RIDGE R32 · 3/4L

Linda Henderson: RSCDS LII 12 · Crib: E-cribs · Diagram: Keith Rose's Diagrams

- 1-- 1c turn RH | cast (2c up) ; 1W+2c & 1M+3c RHA, 1c facing 1cnrs at end
- 9-- Corners Pass and Turn, on [16] 1c pull Rsh back to finish BtoB in centre facing opposite side
- 17-- DTr, on [23-24] 1c Petronella turn to 2pl (2,1,3)
- 25-- Circle6 and back

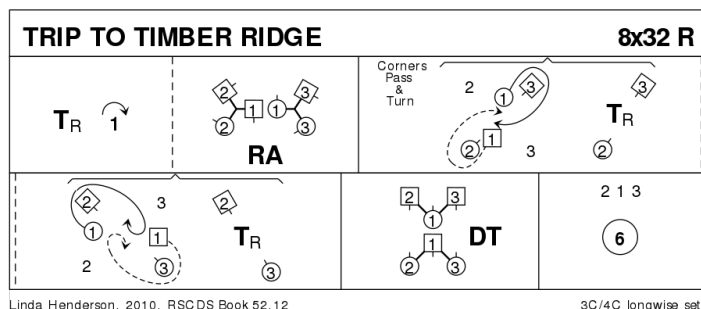

9 FAIR DONALD S32 · 3/4L

RSCDS XXIX 4 · Crib: E-cribs · Diagram: Keith Rose's Diagrams

- 1-- 1c dance NHJ between 2c and cast up to top ; dance NHJ between 3c and cast up to 1cnrs (2c up on [7-8])
- 9-- Reel4 with 1cnrs, at the end pass Lsh to face 2cnrs
- 17-- Reel4 with 2cnrs, finishing between 2c on own side, facing up NHJ
- 25-- 1c cast off one | 2c+1c+3c set ; all turn P BH

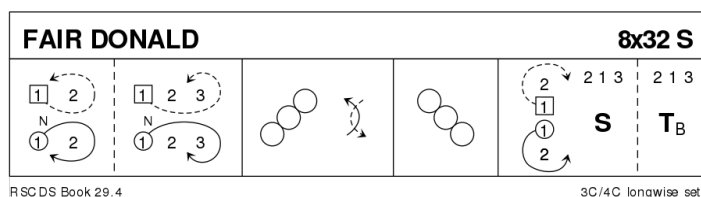

10 BETHANKIT J32 · 3/4L

Moira Stacey: A Third Book of Graded Scottish Country Dances · Crib: E-cribs · Diagram: Keith Rose's Diagrams

- 1-- 1c set | cast off (2c up) ; 1c ½ Fig8 round 2c (2,1x,3)
- 9-- 2c+1M & 1W+3c Reel3 across, Lsh to 3cnr (2,1x,3)
- 17-- 1c set | turn RH ¾ ; 2c+1M & 1W+3c LHA to (2,1,3)
- 25-- 2c+1c R&L (2,1,3)

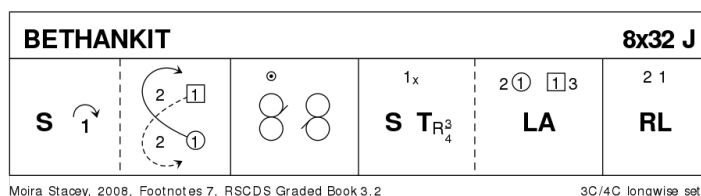

11 THE MERRY LAD'S AFFAIR R32 · 3/4L

Tim Wilson: Just Desserts · Crib: E-cribs

- 1-- 1c cross RH | cast (2c up) ; all A&R (2,1,3)
- 9-- ½ Reels3 on sidelines, 1c Lsh to 1cnrs, cnrs looping at end ; 1c cross RH | cast R into facing lines3 across
- 17-- All A&R ; ½ Reels3 across, 1c Lsh to 2cnrs[pos], finishing BtoB facing 3cnrs[pos]
- 25-- ½ Reel4 on 1diag, pass Lsh to face 4cnrs[pos] ; ½ Reel4 on 2diag to 2pl (2,1,3)

12 FLIGHTS OF FANCY J32 · 3/4L

Jeanetta McColl: Celebrate Fifty Years of Dancing with the Boston Branch · Crib: E-cribs · Diagram: Keith Rose's Diagrams

- 1- 1c+3c set, turn $\frac{3}{4}$ RH into ; $\frac{1}{2}$ Reel4 on mid-line
- 9- 1c (W leading) & 3c (M leading) chase clw to own places **while{4}** 2c Turn RH ; all chase clw $\frac{1}{2}$ to (3x,2x,1x)
- 17- 3c+2c half R&L (no polite turn) ; 3c+1c half R&L (to 2,1,3x)
- 25- 1c $\frac{1}{2}$ Fig8 down (round 3c) ; 1c+3c set and cross RH (2,1,3)

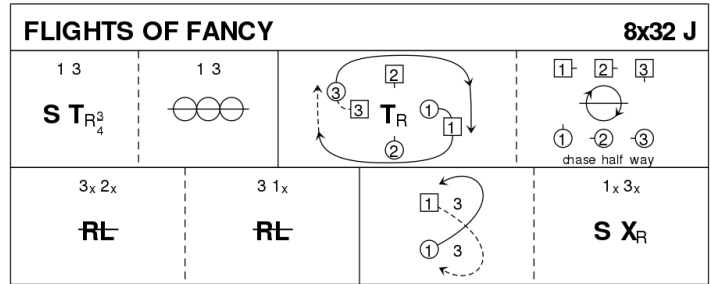

Jeanetta McColl, 1998, Boston Branch 50 Years

3C/4C longwise set.

13 THE HARE REEL R32 · 3/4L

John Roby: Houston & District 30th Anniversary Collection · Crib: MiniCribs · Diagram: Keith Rose's Diagrams

- 1-4 1s+2s set facing each other up/down dance & change places (Men LH, Ladies RH) **while** 3s facing partner set & cross RH
- 5-8 1s+3s set facing each other up/down dance & full turn (Men RH, Ladies LH) **while** 2s facing partner set & cross RH. (2)1(3)
- 9-16 1s dance reflection reels of 3 on sides (1s dancing in & up)
- 17-24 1s dance 1/2 Fig of 8 up around 2s ending in 2nd place, all set & cross RH
- 25-32 All circle 6H round & back

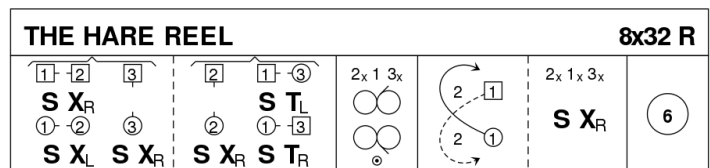

John Roby, 2008, Houston & District 30th Anniversary Collection

3C/4C longwise set.

14 SLYTHERIN HOUSE S32 · 3/4L

Chris Ronald: RSCDS LII 3 · Crib: E-cribs · Diagram: Keith Rose's Diagrams

- 1-- 1c+2c S&Link ; Circle4 L (2,1,3)
- 9-- 1c cast clw round 3c, pass Lsh up/down, cast Lsh round 1c and turn P LH to midline, M below W
- 17-- 2c+1W & 1M+3c RHA ; (Snake) 1W+2W+2M & 1M+3M+3W unwind, pass the other dancers Lsh and loop L to (3,1,2)
- 25-- 3c+1M & 1W+2C LHA ; (Snake) 1W+2W+2M & 1M+3M+3W unwind, pass the other dancers Rsh and loop R to (2,1,3)

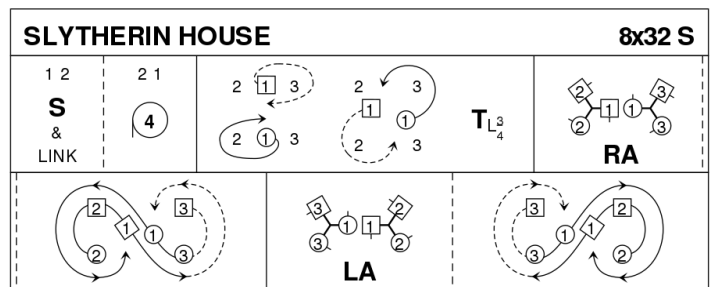

Chris Ronald, 2016, RSCDS Book 52.3

3C/4C longwise set.

15 THE WOODEN HORSE J32 · 3/3L

John Drewry: *The Turkish Set* · Crib: *MiniCrib*s · Diagram: *Keith Rose's Diagrams*

- 1-8** 1s cross RH & cast 1 place **while** 2s set & dance up, 1s turn 2s on sides with nearer hand
- 9-16** 1s cross RH & cast down 1 place **while** 3s set & dance up 1 place, 1s turn 3s on sides with nearer hands
- 17-24** 1s cross up to dance reels of 3 on opposite sides & end 2 3 (1)
- 25-32** 1s dance 1/2 Fig of 8 round 3s & all turn partners RH

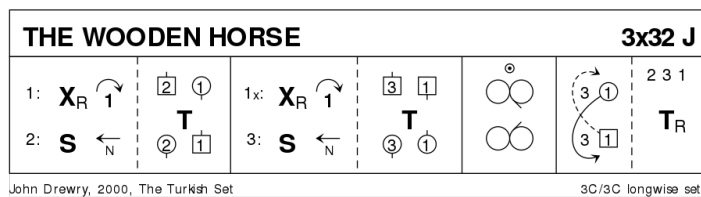

16 THE DEIL AMANG THE TAILORS R32 · 3/4L

RSCDS XIV 7 · Crib: *E-cribs* · Diagram: *Keith Rose's Diagrams*

- 1-** 1c+2c set, 1/2 RHA ; set, 1/2 LHA
- 9-** 1c lead down the middle and up, 2c step in for
- 17-** 1c+2c Allemande
- 25-** 2c+1c+3c circle6 and back.

